

## Product Features

- All stainless steel body and guide piping fittings
- Sensitive and precise pressure control
- Small volume and light weight
- Easy regulation and maintenance
- Excellent sealing performance
- Built-in strainer, to prevent the guide piping system from being blocked

PR300S lightweight pressure reducing valve can automatically reduce high pressure at the inlet to a stable low pressure at the outlet, regardless of changes in fluid velocity or inlet pressure, maintain outlet pressure within the preset range by a precise pressure regulator. When outlet pressure exceeds the set range of the pressure reducing valve, the basic valve body and the pressure regulator will automatically close to form a tight seal.

If the optional check feature is selected, back pressure is generated, and the return fluid will enter the air chamber to close the valve to prevent the fluid from back flow.



**PR300S**

### Material Specifications

**Body/Bonnet:** Stainless Steel

**Disc & Stem:** Stainless Steel

**Piping:** Stainless Steel

**Diaphragm:** EPDM

**Fasteners and Springs:** Stainless Steel

### Working Pressure Range

175PSI/235PSI/350PSI

10Bar/16Bar/25Bar

### Flange Standards

ANSI / BSEN / ISO / DIN

### Temperature/Medium

0°C~100°C normal temperature water

### Pressure Regulator Parameters

**Pressure Regulating Range:** 0.1~5 kgf/cm<sup>2</sup>,  
5~9 kgf/cm<sup>2</sup>, 7~17 kgf/cm<sup>2</sup>

**Pressure Regulator Material:**  
Stainless Steel

### Please Provide the Following Data When Ordering

Valve figure number/size/pressure grade/ connecting end type/pressure regulating range/other optional accessories

\* Note: In valve installation, it is strongly suggested that sufficient space should be left for easy maintenance in the future. A strainer shall be mounted in front of the valve to prevent foreign matters from blocking the valve.

### List of Accessories

- ① Strainer (Built-In)
- ② Ball Valve
- ③ Needle Type Regulating Valve
- ④ Ball Valve
- ⑤ Pressure Reducing Valve
- ⑥ Ball Valve
- ⑦ Body

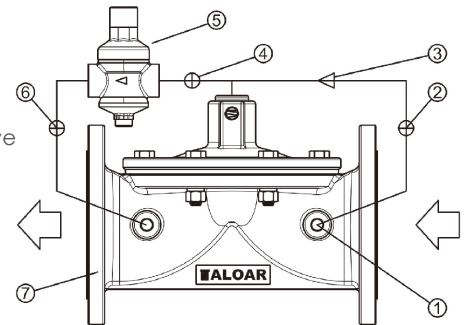

Piping Diagram

### Typical Applications

If flow demand varies in a large range, multiple PR300S pressure reducing valves should be used in parallel. In case of large flow demand, two pressure reducing valves will work simultaneously. In case of small flow demand, the large-sized valve will automatically close, while the small-sized valve will continue to provide the required flow. When setting the pressure regulating range for the valves, the set pressure of the small-sized valve should be about 0.3 kgf/cm<sup>2</sup> higher than that of the large-sized valve.

If the pressure reduction range is large, multiple PR300S pressure reducing valves should be used in series for sectional pressure reduction.

